

TA3020 Audio Amplifier Module v3.10

The TA3020 Audio Amplifier Module is a Class T Stereo Audio Amplifier based on TA3020 digital audio power amplifier driver made by formerly Tripath® Company. The design of this board is in accordance with the manufacturer datasheet and recommendations, as well as the reference designs. Furthermore, some improvements have been made to make the board more compact and suitable to use both in new designs, in which the user will adopt the preferred housing, input stages and power supply, and can be used also as a drop-in replacement for existing audio amplifiers, which already have housing, transformer, and input stage.

Amplifier Features:

- Output Power: 2x200W at 4Ω, or 110W at 8Ω, with max. 0.1% THD+N, at +/- 50V Supply Voltage.
- Output Power: 2x300W at 4Ω, or 160W at 8Ω, with max. 0.1% THD+N, at +/- 55V Supply Voltage.
- Output Power in Bridge mode: 960W at 4Ω or 540W at 8Ω supplied by a matching SMPS.
- Audiophile sound Quality: 0.02% THD+N at 100W at 4Ω or 50W at 8Ω.
- Very good efficiency: Up to 95% at 2x160W at 8Ω or up to 92% at 2x300W at 4Ω.
- Output over-current and short-circuit protected.
- Compact size, 100x100x40mm, assembled board, with integrated heat sink and optional cooling fan.
- Auxiliary supply voltage regulators integrated on board, only need the main symmetric supply voltage.
- Mute control and Mute status pins for controlling the amplifier status within the system.
- Board contains bypass electrolytic capacitors, close to the output stage.
- High current and low R_{DS} on MOS-FETs mounted very close to the TA3020 IC.
- Noise-free Turn On/Off and DC speaker protection included when supplied by a matching SMPS.
- Mostly SMD components used, mounted very close to the TA3020 IC and output MOS-FET's.

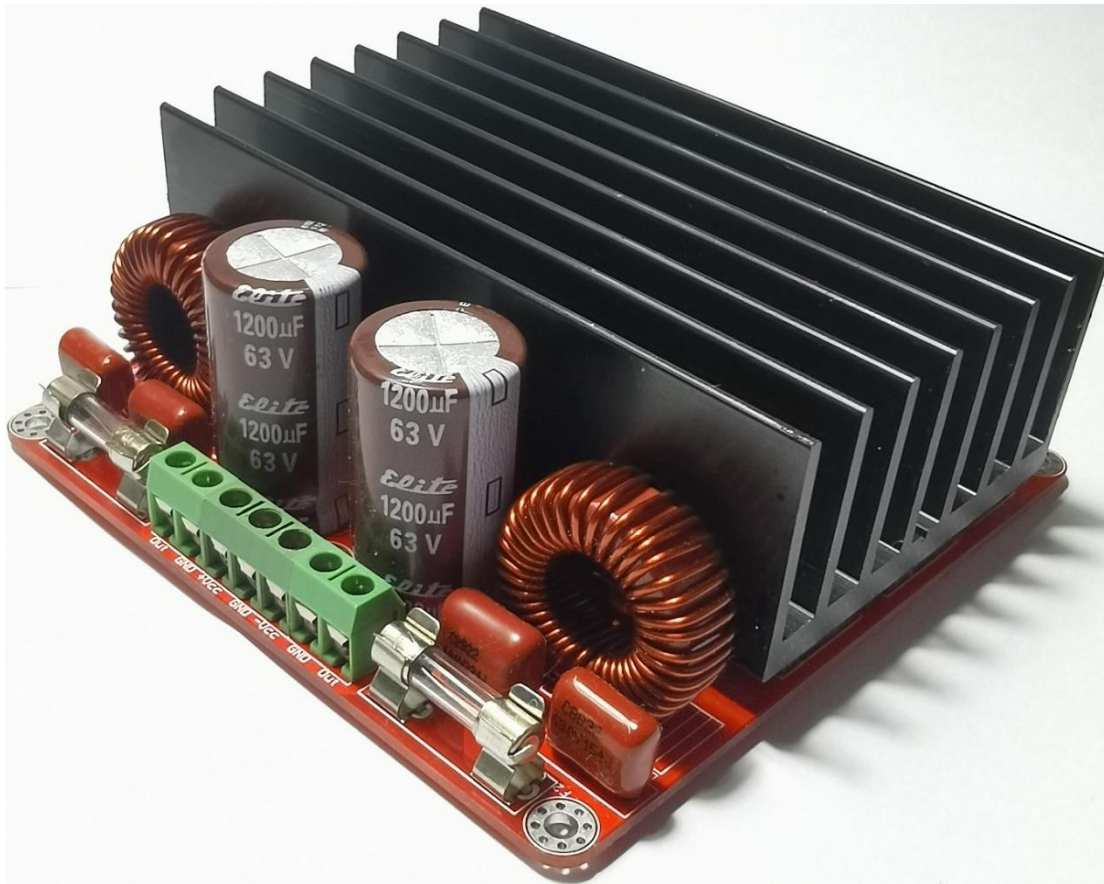

Figure 1: TA3020 Audio Amplifier Module v3.10

Amplifier Description:

TA3020 Class T Stereo Audio Amplifier is built around TA3020, dedicated digital audio power amplifier driver. The main blocks of this amplifier are: Input stage and driver, which uses TA3020 IC, power stage, which uses 4 STW34NB20 MOS-FET's and Auxiliary power supply, which provide power for the drivers, logic and small signal stages. The amplifier schematic is according with the reference design provided by Tripath. In addition to this, the auxiliary switched mode power supply was included onto the schematic. Compared to the previous version, the v3a doesn't have the rectifier bridge and big filtering capacitors integrated on board, this allowing the user to choose the Power Supply which will be more suitable for the application and also reducing board size and weight.

The audio input signal is provided to the TA3020 IC thru the connector P4 at pin 7 for the Left channel and pin 5 for the Right channel. As can be seen from the schematic, the input pins are surrounded by GND pins for better S/N ratio. Next, the audio signal is driven to the TA3020 IC thru DC coupling capacitors, C34 and C37, which should have the value in the range of 1uF to 2.2uF, and can be polarized electrolytic or non-polar metal film. Good results can be achieved with 1uF non-polar metal film capacitors or 2.2uF electrolytic. Next, the resistors R28 and R33 are part of the input stage, and set the amplifier input impedance. The TA3020 input stage is configured as an inverting amplifier, allowing the system designer flexibility in setting the input stage gain and frequency response. The TA3020 amplifier gain is the product of the input stage gain and the modulator gain: $A_{VTA3020} = A_{VINPUTSTAGE} * A_{VMODULATOR}$. For this amplifier, there are two gain values. The TA3020 Class T Stereo Audio Amplifier have the gain value 55V/V which is 34.8dB. The gain can be changed by the user in the range of 15-55 V/V or 23.5-34.8dB by simply changing the value of the resistors R28 and R33. Note that wider gain values are not recommended due to the stability issues which can occurred for higher gain or lower gain values. The gain value can be calculated simply with the following formula: $A_{Left} = 24.66 * R25/R29$ and $A_{Right} = 24.66 * R26/R33$. The coefficient with the value 24.66 is calculated as the ratio of the modulator feedback resistors. The input stage of the amplifier is biased at approximately 2.5V DC using VR1 and VR2 variable resistors. This value is adjusted so that the output DC offset to be as close to 0V as possible (less than 40mV). The DC Offset during mute, and without load will have few volts, but will decrease to 0V after connecting the load. Note that the DC offset was set for the boards after assembly and before test, and does not require further adjustments. For good S/N ratio, is recommended to use shielded signal cables for signal input, and these cables must be as short as possible, and avoid the crossing in close proximity to the power stage or output cables, which can create unwanted feedback. Pay attention to the GND loop which can decrease S/N performances lead to instability and increased output noise.

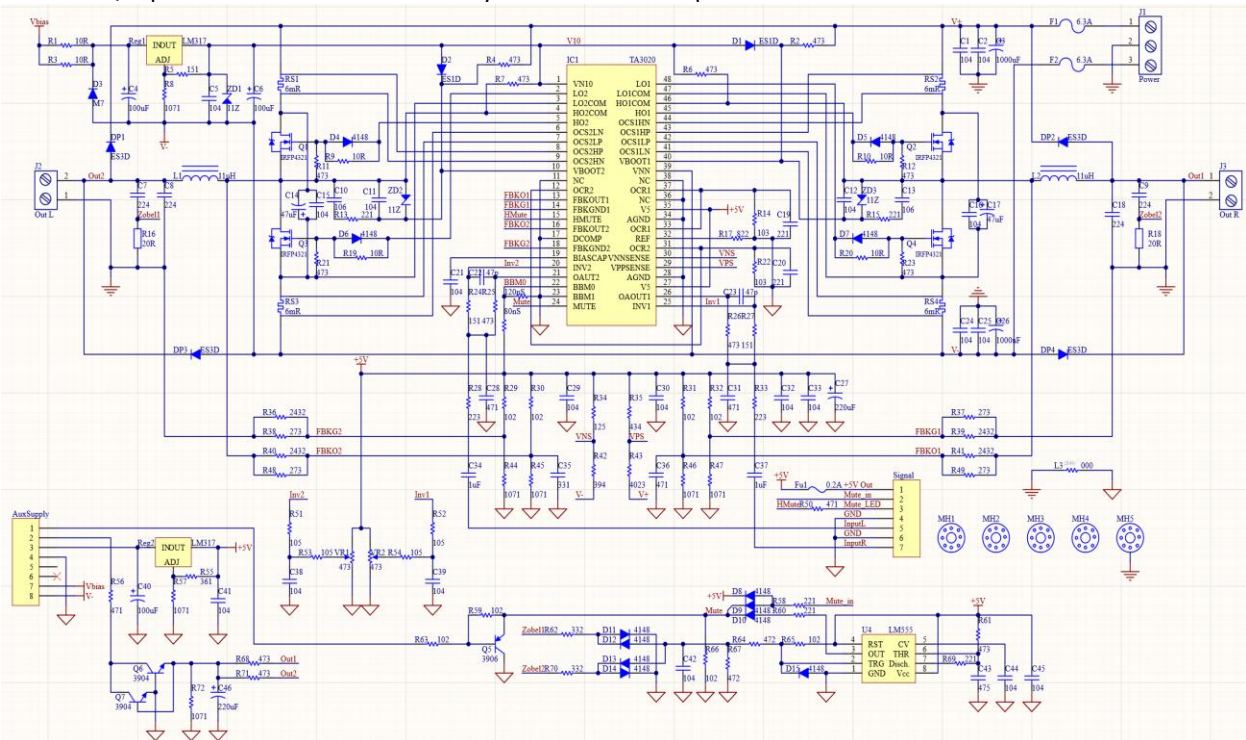

Figure 2: TA3020 v3a Audio Amplifier Module Schematic Diagram

The TA3020v3.10 Audio Amplifier control section consists of Mute circuit, under-voltage, lockout, over-voltage lockout, over-current and short-circuit protection circuits, as can be seen in Figure 2. When a logic high signal is supplied to Mute, on pin 2 of the connector P4, both amplifier channels are muted (both high and low-side transistors are turned off). By default, with the help of an on-board pull-down resistor R47, a logic level low is supplied to MUTE, and both amplifiers are fully operational. There is a delay of approximately 200 milliseconds between the de-assertion of MUTE and the un-muting of the TA3020v3.10 Audio Amplifier. The HMute pin is a 5V logic output that indicates various fault conditions within the device. These conditions include: over-current, overvoltage and under-voltage. The HMute output is capable of directly driving an LED through a series 2k Ω resistor, the board already has a 470 Ω resistor, which can be enough for LEDs with built-in resistors. The TA3020v3.10 Audio Amplifier has built-in over-current protection circuitry to protect itself and the output transistors from short-circuit conditions. The TA3020 uses the voltage across a resistor R_s (measured via OCS1HP, OCS1HN, OCS1LP and OCS1LN) that is in series with each output MOSFET to detect an over-current condition. R_s and R_{OCR} are used to set the over-current threshold. The OCS pins are Kelvin connected for proper operation. When the voltage across R_{OCR} becomes greater than V_{TOC} (approximately 1.0V) the TA3020 will shut off the output stages of its amplifiers. The occurrence of an over-current condition is latched in the TA3020 and can be cleared by toggling the Mute input or cycling power. The $R_s = 10m\Omega$ and $R_{OCR} = 10K\Omega$. At these values, the over-current threshold is set at 27.5 A. For the under-voltage and overvoltage lockout, the TA3020 senses the power rails through external resistor networks connected to VNSENSE and VPPSENSE. The over- and under-voltage limits are determined by the values of the resistors in the networks, and are set within the range of +/- 36V DC to +/- 64V DC. If the supply voltage falls outside the upper and lower limits determined by the resistor networks, the TA3020 shuts off the output stages of the amplifiers. The removal of the over-voltage or under-voltage condition returns the TA3020 to normal operation. Please note that trip points specified in the Electrical Characteristics table are at 25°C and may change over temperature. The TA3020 has built-in over and under voltage protection for both the V+ and V- supply rails. The nominal operating voltage will typically be chosen as the supply “center point.” This allows the supply voltage to fluctuate, both above and below, the nominal supply voltage. VPPSENSE (pin 29) performs the over and under-voltage sensing for the positive supply, V+. VNSENSE (pin 30) performs the same function for the negative rail, V-. When the current through $R_{VPPSENSE}$ or $R_{VNSENSE}$ goes below or above the normal values, (caused by changing the power supply voltage value), the TA3020 will be muted. VPPSENSE is internally biased at 2.5V and VNSENSE is biased at 1.25V. Once the supply comes back into the supply voltage operating range (as defined by the supply sense resistors), the TA3020 will automatically be un-muted and will begin to amplify. There is a hysteresis range on both the VPPSENSE and VNSENSE pins. If the amplifier is powered up in the hysteresis band the TA3020 will be muted. Thus, the usable supply range is the difference between the over-voltage turn-off and under-voltage turn-off for both the V+ and V- supplies. It should be noted that there is a timer of approximately 200mS with respect to the over and under voltage sensing circuit. Thus, the supply voltage must be outside of the user defined supply range for greater than 200mS for the TA3020 to be muted.

The TA3020v3.10 Audio Amplifier driver is integrated in the TA3020 IC, this simplifying the amplifier design. The main role of the driver stage is to provide V_{GS} voltage for the output MOS-FET transistors. The driver stage is powered from the 10V DC with respect to V_{NN} auxiliary supply. The low-side MOS-FETs are driven using the voltage provided, and high-side MOS-FETs are driven using bootstrap supply, which consist of D1, D2, C10, C11, C12, C13, R13, R15. The TA3020 IC contains also the voltage level shifter, for driving the output MOS-FET's which have floating Gate and Source voltages with respect to GND. The driver's pins from the TA3020 IC are connected to the output MOS-FETs through resistors and diodes, (R9, R10, R19, R20, D4, D5, D6, D7) which are used to control MOSFET switching rise/fall times and thereby minimize voltage overshoots. They also dissipate a portion of the power resulting from moving the gate charge each time the MOSFET is switched. If R_g is too small, excessive heat can be generated in the driver. Large gate resistors lead to slower MOSFET switching, which requires a larger break-before-make (BBM) delay. The optimum value of 10 Ω was chosen. The diodes which are connected in parallel with the gate resistors have the role of fast discharging of the gate charge during switch-off, and they must have very fast switching timing. 1N4148 type was chosen, which has very fast switching characteristics, and the maximum peak current is within the diode limits.

The amplifier power stage comprises of 4 Power MOS-FET transistors, which provide the switching function required of a Class-T audio amplifier. They are driven directly by the TA3020 through the gate resistors. The devices used on this amplifier are STW34NB20 or equivalents. The key parameters to consider when selecting which MOSFET to use with the TA3020 are drain-source breakdown voltage (BV_{dss}), gate charge (Q_g), and on-resistance ($R_{DS(ON)}$). The BV_{dss} rating of the MOSFET needs to be selected to accommodate the voltage swing

between V_{SPOS} and V_{SNEG} as well as any voltage peaks caused by voltage ringing due to switching transients. Due to the good circuit board layout, the BV_{dss} is only 20% higher than the V_{PP} and V_{NN} voltage swing, reasonable value. Ideally a low Q_g (total gate charge) and low $R_{DS(ON)}$ are desired for the best amplifier performance. Unfortunately, these are conflicting requirements since $R_{DS(ON)}$ is inversely proportional to Q_g for a typical MOSFET. The design trade-off is one of cost versus performance. A lower $R_{DS(ON)}$ means lower $I_2R_{DS(ON)}$ losses but the associated higher Q_g translates into higher switching losses (losses = $Q_g \times 10 \times 1.2\text{MHz}$). A lower $R_{DS(ON)}$ also means a larger silicon die and higher cost. A higher $R_{DS(ON)}$ means lower cost and lower switching losses but higher $I_2R_{DS(ON)}$ losses.

As optimum MOS-FETs was chosen STW34NB20. The output power MOS-FETs require a dead-time between when one transistor is turned off and the other is turned on (break-before-make setting) in order to minimize shoot through currents. $BBM0$ and $BBM1$ are logic inputs (connected to logic high or pulled down to logic low) that control the break-before-make timing of the output transistors according to the Figure 3:

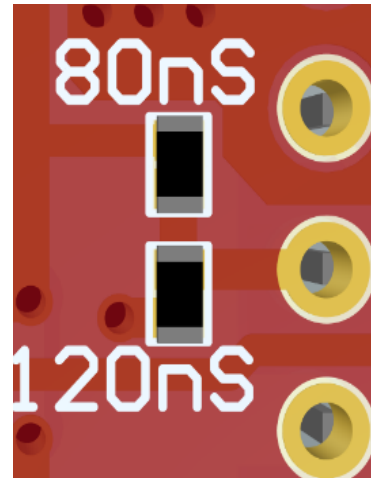

Figure 3: Amplifier BBM Setting

Recommended values for BBM setting are 120nS delay for normal operation, or 80nS for even less THD values. Note that for 80nS the idle current consumption is higher due to increased shoot-through of the MOS-FET transistors. Lower values than 80nS are NOT recommended, because they can lead to lower efficiency, overheating, and eventually failure of the power stage, and there is no increasing in the audio performance more than the case of 80nS setting. For this reason, the $BBM1$ connection was left connected to GND permanently.

Each power MOS-FET has a fast recovery diode connected in parallel for reduction of ringing on the outputs of the MOS-FET transistors. They shunt the inductive energy generated in the parasitic inductance of the components leads and PCB tracks. The diodes are connected close to MOS-FET transistors, in “Drain to Drain” and “Source to Source” topology to minimize the ringing. The diodes are ES2D, SMD type, which have very fast switching timings and very low stray inductance.

Furthermore, for reducing the ringing, few bypass capacitors are placed close to output power MOS-FET’s. There are 2 types of capacitors: one type is X7R material, ceramic capacitors, SMD1206 footprint placed on the bottom side of the PCB, very close to the output MOS-FET’s and the other type are electrolytic capacitors, for energy storage during peaks. The ceramic capacitors are connected between $V+$ and GND, $V-$ and GND and $V+$ to $V-$. They provide extremely low stray inductance and ESR, which is helpful for reducing ringing. Due to the nature of the SMD Ceramic capacitors, they are extremely brittle and easy to crack if the PCB is twisted or bended and when even a tiny crack develops, the capacitor fails catastrophically, often damaging the PCB tracks beneath, so it’s very important to avoid exerting any kind of mechanical tension on the capacitor and at least 15-20mm nearby. Overtightening the screws holding the heatsink can lead to such issue, the screws are already properly tight, do not touch them. The electrolytic capacitors act as energy storage tank during peak power consumption, as well as minimizing the pumping effect which switching amplifiers experience at high power outputs and low frequencies. If the pumping effect is too high, this will lead to amplifier oscillations between ON/OFF states, since the under-voltage and over-voltage protection is not latched shutdown. By using high-capacity electrolytic capacitors, this phenomenon can be reduced. In the unlikely event that this phenomenon still occurs, or when the output power demand is high, as in the BTL mode configuration, should increase the value of the electrolytic capacitors from the external power supply unit which is connected to this board.

After switching stage, the amplified PWM Audio Signal needs to be filtered to extract the audio component. For this purpose, an LC low pass filter is used, with the cut-off frequency at higher value than is used in the classic Class D amplifiers. This greatly reduces the speaker interactions that can occur with the use of lower-frequency filters common in Class-D designs. Also, the higher-frequency operation means that the filter can be of a lower order, simpler and cheaper. The values chosen for the output filter are: Inductance of the filter coil = 11uH, made on Micrometals T94-2 core material, by winding 36 turns of copper wire. Capacitor has the value of 220nF, at a working voltage of at least 250V, for increased reliability. In addition to these components, the filter contains a Zobel Network also, which is required in case that the amplifier is powered without load, to decrease the Q factor of the filter circuit above 50KHz.

The amplifier has a number of redundant protective circuits, which ensure a proper and safe operation. In the unlikely case of a failure, if any other protection fails to respond, and the Power Supply is oversized so that excessive current is supplied, the 2 fuses placed on the edge of the board will act to protect the TA3020v3.10.

The PCB Layout design has an important contribution to the overall performance of the TA3020 Audio Amplifier Module. The tracks width, were calculated to withstand the currents which they have to carry, and also the distance between adjacent tracks which carries higher voltages than 50V is big enough to satisfy the clearance conditions imposed by the design standards. The size of the PCB is 100 x 100 mm, and has 5 mounting holes, 4 holes are on the corner of the PCB and one at the top-middle side of the PCB. The mounting holes are 3.2mm diameter or 0.125-inch, copper plated and reinforced with 8 vias around the main hole, for better mechanical strength. The main components layout and the Input and Output connectors pin out can be seen in the Figure 4. Note that that the central mounting hole is connected to GND. The layout is symmetrical for Left and Right channel with respect to center axis, for best performances and aesthetical reasons.

The TA3020v3.10 Audio Amplifier can be used in bridge mode, with the output power increased considerably. For this, an 180° shifted audio signal with equal amplitude must be provided. The load will be connected between the Left Output and Right Output, without connection to GND. The maximum output power will be about 960W at 4Ω or 540W at 8Ω. Note that at low impedance, the Amplifier can experience over-current protection shut-down, due to the increased current. It is recommended to not use the amplifier at load impedances lower than 4Ω.

The layout and size for the printed circuit board and mounting holes can be seen in the next figure. The heat sink is mounted directly onto the PCB and does not require additional support. The board can be installed in the amplifier case in horizontal position, or vertical position, which is more convenient. Also, the pinout for the input and output connectors can be seen. It is recommended to use heavy gauge wires for Power Supply and Loudspeaker Output and short shielded cables for Audio Input.

TA3020v3.10 Audio Amplifier efficiency is given by the Output Power divided to the Input Power: $\eta = P_{OUT}/P_{IN}$. The Input Power can be considered as: $P_{IN} = P_{DRIVER} + P_{SW} + P_{SMPS} + P_{+5V} + P_{OUT} ((R_S + R_{ON} + R_{COIL} + R_L)/R_L)^2$ where: P_{DRIVER} = Power dissipated in the TA3020 = 1.6W/channel, $P_{SW} = 2 \times (0.01) \times Q_g (Q_g$ is the gate charge of M, in nano-coulombs), R_{COIL} = Resistance of the output filter inductor (typically around 50mΩ), P_{SMPS} = Power dissipated in the Auxiliary power supply, P_{+5V} = Power consumed by a load on the +5V output.

While the Input Power Level can be measured precisely, and the Output Power can also be measured on a resistive load, driving sinus signal, the practical efficiency can be determined. Note that the efficiency is dependent on the Output power level, at low power, has low values, and is increasing as the Output Power is higher.

This is mainly due to switching losses which can be considered constant, and the TA3020 power consumption which can be also considered constant. One factor which greatly influences the switching losses and the global efficiency is the dead-time setting, or BBM setting. The highest efficiency is achieved for a dead-time value of 120nS. From the practical measurements, the average achieved efficiency was up to 95% at 2x160W at 8Ω and up to 92% at 2x300W at 4Ω.

The power MOS-FET transistors requires a heat sink for proper heat dissipation. This is mounted on top of the board over the power MOS-FET transistors and the TA3020 IC, and is fixed with 4 screws which tight the transistors to the heat sink. Two sizes of heatsink are being used: One is 100 mm long, same as the board, 58 mm wide and 30 mm tall, the other one is 100mm long, 60mm wide and 25mm tall. Both heatsinks have longitudinal fins. The thermal resistance of the heat sink is about 3.6-3.8°C/W without forced air cooling, which means an increasing of the heat sink temperature of 3.6-3.8°C for every dissipated Watt. This value can be enough for

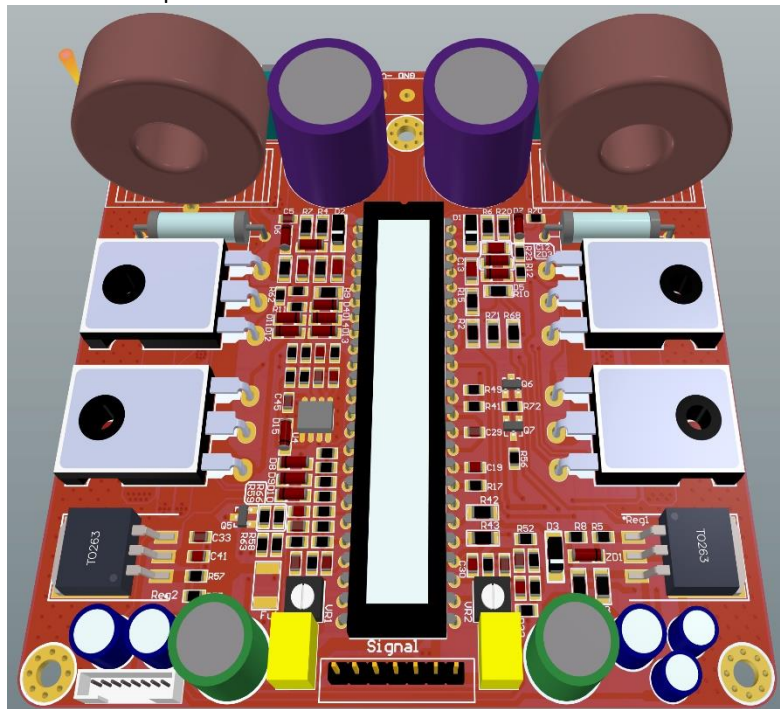

Figure 4: TA3020 Audio Amplifier Module Board layout overview

moderate auditions, considering that the musical signal has a lower power spectrum than the pure sine wave, but the idle power dissipation, especially for BBM values of 80nS should be considered. For better cooling, a standard 5V CPU 60 x 60 mm cooling fan can be used. There are screw holes into the heat sink which can be used for fixing the fan. The power supply can be taken from the small signal connector, which provide +5V. The fan should be mounted with the blow side down, towards the heat sink fins, for better cooling.

To supply the TA3020 Audio Amplifier Module v3.10, must use a Linear or Switching Mode Power Supply which can provide at least +45V at minimum 5A for an Output Power of 2x180W at 4Ω, 95W at 8Ω to +55V at minimum 7.5A for an Output Power of 2x300W at 4Ω, 160W at 8Ω. To ensure the Output Power levels and performances, the power supply voltage should not drop more than 5-10% at maximum power. The onboard electrolytic capacitors, ensure energy storage for peak power levels. It is required to add external capacitors, from an external PSU, linear or SMPS. The TA3020v3.10 Amplifier was designed to take full advantage of the RxE series SMPS features, which include separate supply for the auxiliary voltages, delay Turn On signal, Fast-Shutdown and Latched Shutdown if DC Component is detected on the speaker output. The recommended SMPS is SMPS600RxE +55V for 2x300W at 4Ω, or 160W at 8Ω Output Power. For BTL operation or up to 3 TA3020v3.10 Amplifiers operating in Single-Ended Mode, one SMPS2000RxE +55V is the most suitable choice.

If the end-user still prefers to use a Linear Power Supply board, we recommend using the Power Supply and Protection Circuit (PSPC) which can provide the auxiliary voltages as well. If other Linear Power Supplies are chosen such as LPS212A, LS215A or even LPS220A, the auxiliary voltages must be provided separately. Any of this boards are suitable match, and can provide enough filtering capacity and rectification. The total Capacitance on each rail for Single-Ended operation should be at least 4mF per rail and not more than 15mF per rail. For bridge mode is recommended to provide a current of at least 6A for 2x28V AC supply or 10A for 2x42V AC supply, while the filtering capacitance can be just 2-4mF for each rail if the Power Supply is capable to deliver the required current without significant voltage sag or a regulated SMPS is used.

Important: No matter which kind of Power Supply is used, Linear or SMPS, the Aux voltages and signals must be supplied correctly, otherwise the amplifier will not work properly and damage can occur if incorrect voltages are present. Make sure that suitable voltage levels and signals are supplied.

The Signal input connector pinout:

- Pin 1: +5V Out for Mute Control or any other logic circuitry. Can source 50mA maximum.
- Pin 2: Mute In – a logic 1 on this pin will bring the amplifier in Mute state.
- Pin 3: Mute Status – this pin will toggle to logic 1 is when the amplifier is Muted
- Pin 4: GND Signal
- Pin 5: Input Left – audio signal Input Left
- Pin 6: GND Signal
- Pin 7: Input Right – audio signal Input Right

The AuxSupply Connector Pinout:

- Pin1: Mute Signal, Active Low. Mute the Amplifier during SMPS Turn-On Sequence.
- Pin2: Fast Shutdown Signal, Disable the SMPS Operation if DC Component is detected at Speaker Out.
- Pin3: +Aux output. Auxiliary positive voltage output used for amplifier operation.
- Pin4: GND. Auxiliary differential voltage Ground.
- Pin5: -Aux output. Reserved, used for other amplifiers.
- Pin6: Enable Signal. Reserved, used for other amplifiers.
- Pin7: +Vbias. Positive output of the isolated output voltage used for driver stage.
- Pin8: -Vbias. Negative output of the isolated output voltage used for driver stage.

Disclaimer:

The TA3020v3.10 Audio Amplifier Module shall be used according with the instructions provided in this document. The user should NOT attempt to modify or change any of the parameters of this product, which can lead to malfunction. The designer and manufacturer of the product, **Connexelectronic**, and the official distributors, will not be liable for any kind of loss or damage, including but not limited to incidental or consequential damages. Due to the high level of voltages on this board, the user should take all the caution measures needed when working with high voltage levels, should not touch any uninsulated part of the board or connectors, or short-circuit any part of the board or connectors. Any misuse will be made on user responsibility. **Purchasing the product means that you are aware and agree with all this conditions.**