

TA3020 Audio Amplifier Module v3c

The TA3020v3c Audio Amplifier Module is a complete assembled Class T Stereo Audio Amplifier based on TA3020 digital audio power amplifier driver made by formerly Tripath® Company. The design of this board is in accordance with the manufacturer datasheet and recommendations, as well as the reference designs. Furthermore, some improvements has been made to make the board more compact and suitable to use both in new designs, in which the user will adopt the preferred housing, input stages and power supply, and can be used also as a drop-in replacement for existing audio amplifiers, which already have housing, transformer, input stage, potentiometers or other accessories.

Amplifier Features:

- Output Power: 2x300W at 4Ω, or 160W at 8Ω, with max. 0.1% THD+N, at +/- 56V Supply Voltage for the version equipped with STW34NB20 Power MOS-FET's.
- Output Power: 2x400W at 4Ω, or 205W at 8Ω, with max. 0.1% THD+N, at +/- 61V Supply Voltage for the version equipped with IRFP4321 Power MOS-FET's.
- Output Power in Bridge mode: 1120W at 4Ω or 580W at 8Ω for the version equipped with STW34NB20 and 1520W at 4Ω or 790W at 8Ω for the version equipped with IRFP4321 Power MOS-FET's.
- Audiophile sound Quality: 0.02% THD+N at 100W at 4Ω or 50W at 8Ω.
- Very good efficiency: Up to 95% at 2x160W at 8Ω or up to 90% at 2x300W at 4Ω.
- Compact size, 100x130x40mm, assembled board, with integrated heat sink and optional cooling fan.
- Auxiliary supply voltage regulators integrated on board, only need the main symmetric supply voltage.
- Mute control and Mute status pins for controlling the amplifier status within the system.
- Board contains Rectifier Bridge and large electrolytic capacitors, close to the output stage.
- Double layer, 1.6mm thick PCB with 2 oz copper traces, used mostly SMD components.

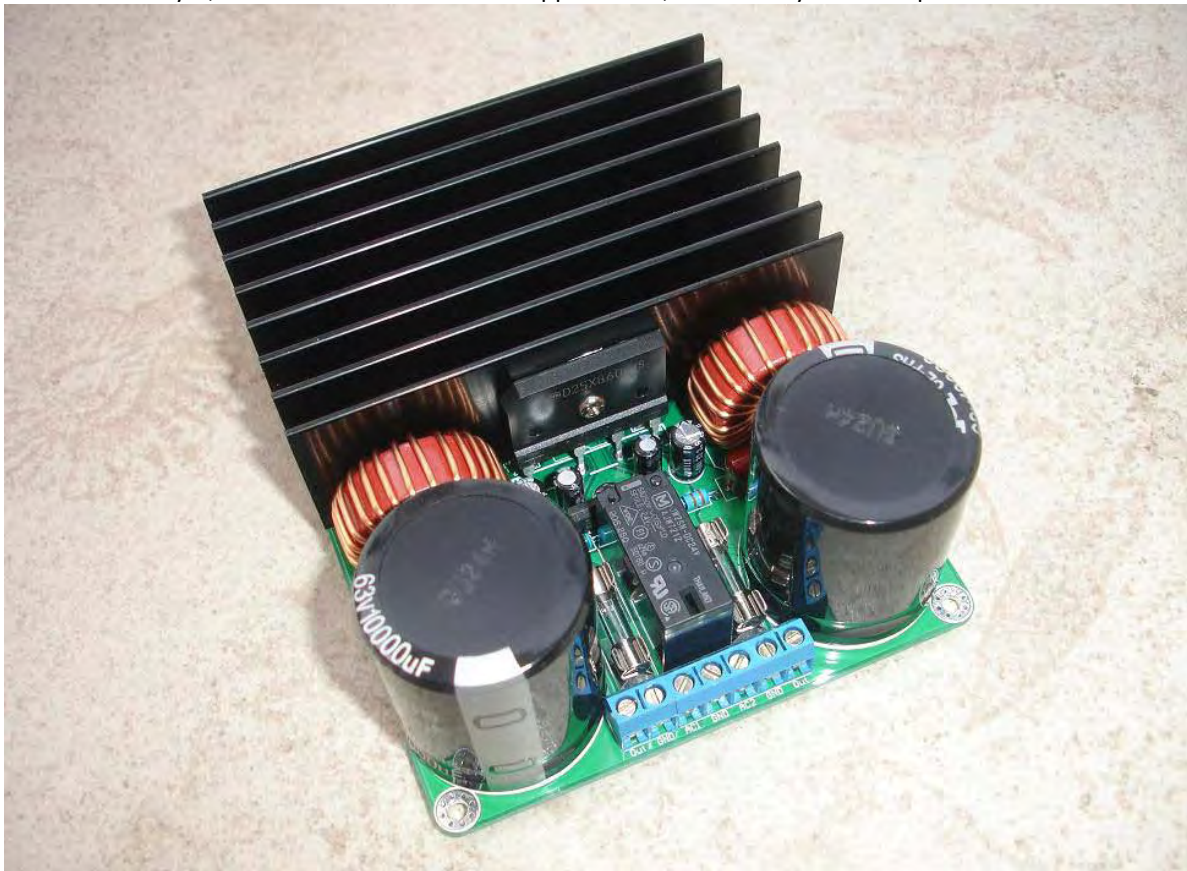

Figure 1: TA3020 Audio Amplifier Module v3c

Amplifier Description:

TA3020 Class T Stereo Audio Amplifier is built around TA3020, dedicated digital audio power amplifier driver. The main blocks of this amplifier are: Input stage and driver, which uses TA3020 IC, power stage, which uses 4 pcs. STW34NB20 or IRFP4228 Power MOS-FET's and Auxiliary power supply, which provide power for the drivers, logic and small signal stages. The amplifier schematic is according with the reference design provided by Tripath. In addition to this, the auxiliary switched mode power supply was included onto the schematic. Compared to the previous versions, the TA3020v3c amplifier board has the rectifier bridge and big filtering capacitors integrated on board, as well as the speaker protection circuit and relay, this allowing the user to build a complete amplifier with minimal external components, reducing the amplifier total size and weight.

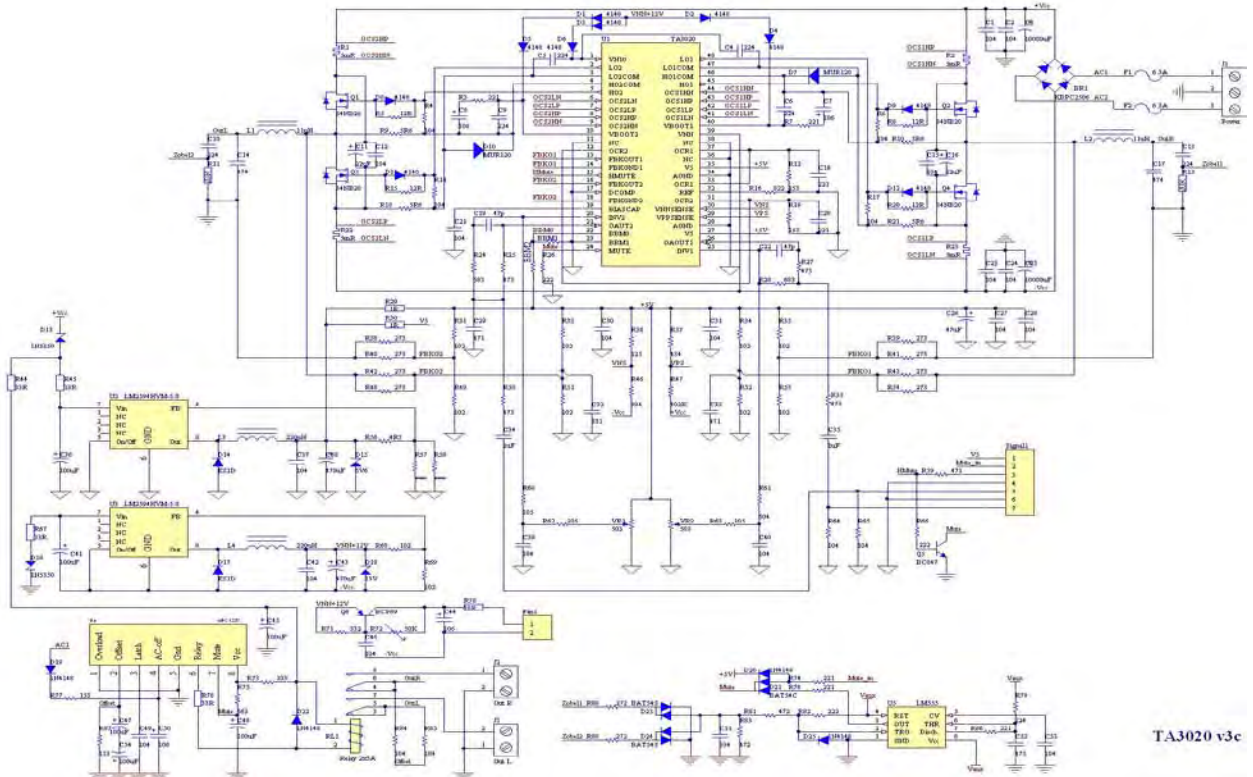

Figure 2: TA3020 v3a Audio Amplifier Module Schematic Diagram

Input Stage: The audio input signal is provided to the TA3020 IC thru the connector P4 at pin 5 for the Left channel and pin 7 for the Right channel. As can be seen from the schematic, the input GND pins are pin 4 and pin6. Next, the audio signal is driven to the TA3020 IC thru DC coupling capacitors, C34 and C35, which should have the value in the range of 1uF to 4.7uF, and can be polarized electrolytic or non-polar metal film. Good results can be achieved with 1uF non-polar metal film capacitors, or 2.2uF electrolytic. Next, the resistors R50 and R55 are part of the input stage, and set the amplifier input impedance and gain. The TA3020 input stage is configured as an inverting amplifier, allowing the system designer flexibility in setting the input stage gain and frequency response. The TA3020 amplifier gain is the product of the input stage gain and the modulator gain: $A_{VTA3020} = A_{VINPUTSTAGE} * A_{VMODULATOR}$. For this amplifier, there are two gain values. Some boards have the gain value 15V/V which is 23.5dB and some boards have the gain value 5.88V/V which is 15.4dB. On request different values can be provided, or the gain can be changed by the user in the range of 5-15 V/V or 14-23.5dB by simply changing the value of the resistors R25, and R28. Note that wider gain values are not recommended due to the stability issues which can occurred for higher gain or lower gain values. The gain value can be calculated simply with the following formula: $A_{Left} = 20 * R25 / R50$ and $A_{Right} = 20 * R28 / R55$. The coefficient with the value 15 is calculated as the ratio of the modulator feedback resistors. The input stage of the amplifier is biased at approximately 2.5V DC using VR1 and VR2 variable resistors. This value is adjusted so that the output DC offset to be as close to 0V as possible (less than 40mV). The DC Offset during Mute, and without load will be about 2.5V due to the feedback loop bias resistors,

and will decrease to adjusted value, close to 0V after connecting the load. Note that the DC offset is already set for the boards after assembly, and does not require further adjustments. A DC offset larger than 100mV can lead to excessive bus pumping, and must be avoided. For good S/N ratio, it is recommended to use very short shielded signal cables for signal input, and avoid the crossing in close proximity to the power stage or output cables, which create unwanted feedback. Pay attention to the GND loop which can decrease S/N performances lead to instability and increased output noise.

Mute control: When a logic high signal is supplied to Mute, on pin 1 of the Signal connector, both amplifier channels are muted (both high and low-side transistors are turned off). By default, with the help of an on-board pull-down resistor R54, a logic level low is supplied to MUTE, and both amplifiers are fully operational. There is a delay of approximately 200 milliseconds between the de-assertion of MUTE and the un-muting of the TA3020 Audio Amplifier Module. The HMute pin is a 5V logic output that indicates various fault conditions within the device. These conditions include: over-current, overvoltage and under-voltage. The HMute output is capable of directly driving an LED through a series 2k Ω resistor, the board already has a 470 Ω resistor, which can be enough for LED's with built-in resistors.

Overcurrent Protection: The TA3020 Audio Amplifier Module has built-in over-current protection circuitry to protect itself and the output transistors from short-circuit conditions. The TA3020 uses the voltage across a resistor R_s (measured via OCS1HP, OCS1HN, OCS1LP and OCS1LN) that is in series with each output MOSFET to detect an over-current condition. R_s and R_{OCR} are used to set the over-current threshold. The OCS pins are Kelvin connected for proper operation. When the voltage across R_{OCR} becomes greater than V_{TOC} (approximately 1.0V) the TA3020 will shut off the output stages of its amplifiers. The occurrence of an over-current condition is latched in the TA3020 and can be cleared by toggling the Mute input or cycling power. The $R_s = 7.5m\Omega$ and $R_{OCR} = 10K\Omega$. At this values, the over-current threshold is set at 36 A.

Under-voltage and Overvoltage Protection: The TA3020 senses the power rails through external resistor networks connected to VNSENSE and VPPSENSE. The under-voltage and over-voltage thresholds are determined by the values of the resistors in the networks, and are set within the range of +/- 36V DC to +/- 64V DC. If the supply voltage falls outside the upper and lower limits determined by the resistor networks, the TA3020 shuts off the output stages of the amplifiers. The removal of the over-voltage or under-voltage condition returns the TA3020 to normal operation. Please note that trip points specified in the Electrical Characteristics table are at 25°C and may change over temperature. The TA3020 has built-in over and under voltage protection for both the V+ and V- supply rails. The nominal operating voltage will typically be chosen as the supply "center point." This allows the supply voltage to fluctuate, both above and below, the nominal supply voltage. VPPSENSE (pin 29) performs the over and under-voltage sensing for the positive supply, V+. VNSENSE (pin 30) performs the same function for the negative rail, V-. When the current through $R_{VPPSENSE}$ or $R_{VNSENSE}$ goes below or above the normal values (caused by changing the power supply voltage value), the TA3020 will be muted. VPPSENSE is internally biased at 2.5V and VNSENSE is biased at 1.25V. Once the supply comes back into the supply voltage operating range (as defined by the supply sense resistors), the TA3020 will automatically be un-muted and will begin to amplify. There is a hysteresis range on both the VPPSENSE and VNSENSE pins. If the amplifier is powered up in the hysteresis band the TA3020 will be muted. Thus, the usable supply range is the difference between the over-voltage turn-off and under-voltage turn-off for both the V+ and V- supplies. It should be noted that there is a timer of approximately 200ms with respect to the over and under voltage sensing circuit. Thus, the supply voltage must be outside of the user defined supply range for greater than 200ms for the TA3020 to be muted.

Driver Stage: The TA3020 Audio Amplifier Module driver is integrated in the TA3020 IC, this simplifying the amplifier design. The main role of the driver stage is to provide V_{GS} voltage for the output MOS-FET transistors. The driver stage is powered from the 10V DC with respect to V_{NN} auxiliary supply. The low-side MOS-FET's are driven using the voltage provided, and high-side MOS-FET's are driven using bootstrap supply, which consist of D1-D6, D2, C4, C5, C6, C7, C8, C9, R3, R7. The TA3020 IC contains also the voltage level shifter, for driving the output MOS-FET's which have floating Gate and Source voltages with respect to GND. The driver's pins from the TA3020 IC are connected to the output MOS-FET's through resistors and diodes, (R5, R8, R15, R20, D8, D9, D11, D12) which are used to control MOSFET switching rise/fall times and thereby minimize voltage overshoots. They also dissipate a portion of the power resulting from moving the gate charge each time the MOSFET is switched. If R_G is too small,

excessive heat can be generated in the driver. Large gate resistors lead to slower MOSFET switching, which requires a larger break-before-make (BBM) delay. The optimum value of 5.6Ω was chosen for STW34NB20 Power MOS-FET's and 13.5Ω for IRFP4228 Power MOS -FET's. The diodes which are connected in parallel with the gate resistors have the role of fast discharging of the gate charge during switch-off, and they must have very fast switching timing. 1N4148 type was chosen, which has very fast switching characteristics, and the maximum peak current is within the diode limits. Also the dynamic resistance of the diodes helps in limiting the discharge current of the MOS-FET's gates.

Power Stage: The amplifier power stage comprises of 4 Power MOS-FET transistors, which provide the switching function required of a Class-T audio amplifier. They are driven directly by the TA3020 through the gate resistors. The devices used on this amplifier are STW34NB20 for the standard amplifier version and IRFP4228 for the upgraded amplifier version. The key parameters to consider when selecting which MOSFET to use with the TA3020 are drain-source breakdown voltage (BVdss), gate charge (Qg), and on- resistance ($R_{DS(ON)}$). The BVdss rating of the MOSFET needs to be selected to accommodate the voltage swing between V_{SPOS} and V_{SNEG} as well as any voltage peaks caused by voltage ringing due to switching transients. Due to the good circuit board layout, the BVdss is only 20% higher than the VPP and VNN voltage swing, reasonable value. Ideally a low Qg (total gate charge) and low $R_{DS(ON)}$ are desired for the best amplifier performance. This ration is often called FOM of a MOS-FET (Figure of Merit). Unfortunately, these are conflicting requirements since $R_{DS(ON)}$ is inversely proportional to Qg for a typical MOSFET. The design trade-off is one of cost versus performance. A lower $R_{DS(ON)}$ means lower $I_2R_{DS(ON)}$ losses but the associated higher Qg translates into higher switching losses (losses = $Qg \times 10 \times 1.2MHz$). A lower $R_{DS(ON)}$ also means a larger silicon die and higher cost. A higher $R_{DS(ON)}$ means lower cost and lower switching losses but higher $I_2R_{DS(ON)}$ losses. Thus the IRFP4228 was chosen for the upgraded amplifier version since it has one of the best FOM for the 150V MOS-FET's.

Dead-time: The output power MOS-FET's require a so called dead-time between the moment when one transistor is turned off and the other one is turned on in order to minimize shoot through currents. The amplifier uses the Break-before-make setting, BBM0 and BBM1 which are logic inputs (connected to logic high or pulled down to logic low) that control the break-before-make timing of the output transistors according to the required dead-time for proper amplifier operation and minimum THD values.

Recommended values for BBM setting are 120mS normal operation, or 80nS for even less THD values. Note that for 80nS the idle current consumption is higher due to increased shoot-through of the MOS-FET transistors. Lower values than 80nS are NOT recommended, because they can lead to lower efficiency, overheating, and eventually failure of the power stage, and there is no significant increase in the audio performance more than the 80nS setting. For this reason, the BBM1 connection was left connected to GND permanently. Typical values for the BBM settings are 120nS for the STW34NB20 amplifier version and 80nS for the IRFP4228 amplifier version.

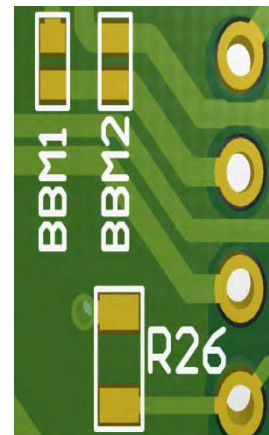

Figure 3: Amplifier BBM Setting

EMI Reduction: For reducing the ringing, and radiated EMI, as well as improving the amplifier reliability, few bypass capacitors are placed close to output power MOS-FET's. There are 2 types of capacitors: one type is X7R material, ceramic capacitors, SMD1206 footprint placed on the bottom side of the PCB, very close to the output MOS-FET's and the other type are electrolytic capacitors, for energy storage during peaks. The ceramic capacitors are connected between V_+ and GND, V_- and GND and V_+ to V_- . They provide extremely low stray inductance and ESR, which is helpful for reducing ringing. The electrolytic capacitors acts as energy storage tank during peak power consumption, as well as minimizing the pumping effect which switching amplifiers experience at high power outputs and low frequencies. If the pumping effect is too high, this will lead to amplifier oscillations between ON/OFF states, since the under-voltage and over-voltage protection is not latched shutdown. By using high-capacity electrolytic capacitors, this phenomenon can be reduced. In the unlikely event that this phenomenon still occur, or when the output power demand is high, as in the BTL mode configuration, should increase the value of the electrolytic capacitors from the amplifier board, or use an external power supply unit is connected to this board, by bypassing the rectifier bridge. The Power Supply board which can be used is PS10K63, PS10K80, or even

PS18K71. If an SMPS is the preferred choice, the A1000SMPS or the SMPS500 are suitable for this amplifier, depending on the required output power. In case of using an external Power supply, either linear or SMPS, bypassing the rectifier bridge is strongly recommended to eliminate the voltage drop and adding more capacitance to the voltage rails.

Output Filter: After switching stage, the amplified PWM Audio Signal needs to be filtered to extract the audio component. For this purpose an LC low pass filter is used, with the cut-off frequency at higher value than is used in the classic Class D amplifiers. This greatly reduces the speaker interactions that can occur with the use of lower-frequency filters common in Class-D designs. Also, the higher-frequency operation means that a lower order filter with lower losses and better performances can be used. The values chosen for the output filter are: Inductance of the filter coil = 11uH, made on Micrometals T106-2 core material, by winding 30 turns of 1.2 mm (16AWG) copper wire. Capacitor has the value of 220nF, at minimum 250V working voltage, for increased reliability. In addition to this components, the filter contains a Zobel Network also, which is required in case that the amplifier is powered without load, to decrease the Q factor of the filter circuit above 50KHz and damp the oscillations which may occur in some situations. An important aspect of the output filter is that, although the amplifier uses a pre-filter feedback topology, the switching frequency and filter cut-off frequency gives this amplifier remarkable performances, comparable with the top-end post-filter feedback class D amplifiers, which has almost flat and load independent frequency response and a high damping factor, enabling the amplifier to drive large low-impedance subwoofers without degrading the performances.

Power Supply: To supply power to the TA3020 Audio Amplifier Module v3c, there are few choices:

- **Mains transformer:** with the output voltage in range of 2x30V AC to 2x43V AC at minimum 5A for the lower power version or 8A for the higher power version. The onboard rectifier bridge and electrolytic capacitors ensures proper operation for all the power levels up to 400W/channel. To be able to deliver the maximum output power, the amplifier must use the largest available capacitors, the 18,000uF 71V ELNA type capacitors. Also the transformer must be able to deliver 2x42V AC at minimum 8A. A higher AC voltage than 2x43V AC is not recommended, because after rectifying and filtering will get more than +- 61V DC which is close to the overvoltage threshold and the amplifier is likely to Mute when the Bus-pumping will occur if the filtering capacitors are below 15,000uF for each rail, or the Balanced Input Phase Shifter module (BIPS) is not used.
- **External linear supply board:** such as PS10K63, PS10K80, or even PS18K71 which can be used to supply power for up to 3 amplifiers. In this case the rectifier bridge from the board must be bypassed to avoid the voltage drop and to have a cumulate total capacitance much larger, which helps a lot when playing low-frequency large amplitude signal and reduce the Bus-pumping.
- **SMPS:** the advantage of using a SMPS instead of a mains transformer are reduced weight, smaller size and better performance compared to a mains-transformer, when using a regulated SMPS such as A1000SMPS which translate in tighter bass, and more accurate medium-high frequency reproduction.

Auxilliary Supply: The amplifier contains the auxiliary power supply which provides the housekeeping supply voltages needed for proper amplifier operation. The values of this are: +5V DC with respect to GND and +10V DC with respect to V-. Also, a positive voltage in the range of 40-47V derived from the main positive voltage is available to be used for the speaker protection circuit relay. One of the main characteristic of Class T Amplifiers is high efficiency. For this, a switch mode power supply was chosen. This power supply consists of two similar stages, one for each needed voltage. The main component of the power supply is: LM2594HVS, 52kHz, 0.5A Buck Regulator with maximum input voltage of 60V DC, the inductor and fast recovery diode. In addition to this components, the power supply has few redundant Zenner diodes which protect the TA3020 IC in case of overvoltage or failure of the power supply IC. To extend the maximum input voltage of the power supply IC's, 13V Zenner diodes were connected in series with the input voltage. Due to the nature of the regulators, the input current is much less than the output current, so the dissipated power on the Zenner diodes have very small value. Also, at the output of each regulator, protective Zenner diodes were connected, with the working voltage of 15-20% higher than the nominal voltage, to protect the TA3020 IC in case of power supply failure. The amplifier has a number of redundant protective circuits, which ensure a proper and safe operation. In the unlikely event of a major failure, if all of the protection fails to respond, the fuses will act to protect the board and the power supply. There are 2 pcs. 10A fuses, one for each supply rail, placed on the edge of the board.

Power Soft Start: An important aspect which must be considered when the amplifier is powered from a mains transformer, either connected directly to the amplifier board, or through an external linear supply board, is the **Power ON Inrush current**, which has the function to limit the inrush current drawn from the mains by the transformer of the amplifier during power ON sequence. When the power amplifier is switched on, the initial current drawn from the mains is few times higher than the maximum current which is drawn at the full power. There are two main reasons for this: one reason is because the transformers will draw a very heavy current at switch on, until the magnetic flux has stabilized. The effect is worst when power is applied as the AC voltage passes through zero, and is minimized if power is applied at the peak of the AC waveform. This is exactly the opposite of what you might expect. Another reason is that at power on, the filter capacitors are completely discharged, and act as a short circuit for a brief (but possibly destructive) period. The current is higher as the capacitor stored energy ($CU^2/2$). The **Power Soft Start** is **NOT** required for the **SMPS** since they already have built-it soft start, just for the mains transformers.

Peaking Detection Circuit. If the amplifier is operated without load connected or in certain operation conditions, when the amplifier is operated beyond his limits, as explained on the last page, the output filter can experience the **Peaking** phenomenon which lead to higher voltage than supply voltage build-up on output power stage with possible damage if measures are not taken to reduce or eliminate this. The **Peaking Detection Circuit** will detect the peaking of the output filter of the class D or T amplifier, a phenomenon which might have destructive effect if large amplitude is developed at the output of the amplifier. The main cause of the peaking is the resonance of the output LC low-pass filter components when the input signal amplified has high frequency and high amplitude, or in case of abnormal operation, when oscillation of the output power stage is experienced. During peaking, the output filter of the amplifier resonate at or close to its resonance frequency, very large currents is flowing through the filter components, and the amplitude of the voltages on the filter components can exceed the supply voltage rails, which can damage the power stage if measures to damp the oscillation are not taken. The **Peaking Detection Circuit** detects the maximum amplitude of the output signal of the amplifier and Mute the amplifier if a specific threshold is reached. Unlike the DC component which can be detected by the speaker protection circuit, the peaking has high frequency components which would not be detected by the speaker protection circuit, and is also not desired to disconnect the speakers during peaking even, but rather Mute the amplifier instead. The threshold for peaking amplitude and frequency is determined by the values of the following components: C51, R80, R88 and R83. With the current values, the peaking will be detected when the output signal amplitude will exceed 0.75xV supply at 26KHz. Note that this amplitude at this particular frequency is much higher than the amplitude of any musical signal, and below the dangerous level for the amplifier.

When **peaking** is detected on any of the two channels, Mute is asserted and a timer is started which will un-Mute the amplifier after about 2-3 seconds, after the oscillation has been damped already. If the peaking persists, the cycle will repeat.

Bus Pumping: An unwanted and potentially troublesome phenomenon in single-ended Class D and Class T amplifiers is the power supply pumping effect. It is caused by the flowing of the current from the output filter inductor into the power supply filter capacitors in opposite direction as the DC load sink current. The phenomenon is more evident at low-frequency and high amplitude signals, and if is not prevented it will trip the Overvoltage protection circuit, causing the amplifier to enter in Mute state until the supply voltage drop below the lower overvoltage protection threshold. Another cause of the Bus pumping is the DC offset which if is larger than 100-200mV, opposite voltage rail will start increasing the voltage until the Overvoltage protection circuit will trip, and Mute the amplifier. There are 2 solutions to reduce the Bus-pumping. The first solution is to use large Electrolytic capacitors on each power supply voltage rail to absorb the pumped supply current and to use-it in the next switching cycle. This method is less efficient when the output amplitude increase and the frequency decrease, being ineffective with DC signal. The best solution to avoid Bus-Pumping is to drive one amplifier channel 180° out of phase with respect to the other. This setup will reduce the Bus-pumping because each channel is pumping out of phase with the other, and the net effect is a cancellation of pumping currents in the power supply. The phase of the audio signals needs to be corrected by connecting one of the speakers in the opposite polarity as the other channel. To achieve the phase shift, the Balanced Input Phase Shifter module (BIPS) must be used. This also has both balanced and unbalanced inputs, suitable for using the amplifier with differential audio signal input. Bus-pumping doesn't occur in BTL mode if the amplifier is driven symmetrically.

Amplifier Efficiency: The TA3020 Audio Amplifier Module efficiency is given by the Output Power divided to the Input Power: $\eta = P_{OUT}/P_{IN}$. The Input Power can be considered as:

- $P_{IN} = P_{DRIVER} + P_{SW} + P_{SMPS} + P_{+5V} + P_{OUT} ((R_s + R_{ON} + R_{COIL} + R_L)/R_L)^2$ where:
- P_{DRIVER} = Power dissipated in the TA3020 = 1.6W/channel,
- $P_{SW} = 2 \times (0.01) \times Q_g$ (Q_g is the gate charge of M, in nano-coulombs),
- R_{COIL} = Resistance of the output filter inductor (typically around 50m Ω),
- P_{SMPS} = Power dissipated in the Auxiliary power supply

While the Input Power Level can be measured precisely, and the Output Power can also be measured on a resistive load, driving sinus signal, the practical efficiency can be determined. Note that the efficiency is dependent on the Output power level, at low power, has low values, and is increasing as the Output Power is higher.

This is mainly due to switching losses which can be considered constant, and the TA3020 power consumption which can be also considered constant. One factor which greatly influences the switching losses and the global efficiency is the dead-time setting, or BBM setting. The highest efficiency is achieved for a dead-time value of 120nS. From the practical measurements, the average achieved efficiency was up to 95% at 2x160W at 8 Ω and up to 90% at 2x300W at 4 Ω .

Thermal management: The power MOS-FET transistors requires a heatsink for proper heat dissipation. This is mounted on top of the board over the power MOS-FET transistors and the TA3020 IC, and is fixed with 4 screws which tight the transistors to the heat sink. The heatsink has 100 mm long, same as the board, 58 mm wide and 30 mm tall, and has 8 fins. The thermal resistance of the heat sink is about 4.8 $^{\circ}$ C/W without forced air cooling, which means an increasing of the heat sink temperature of 4.8 $^{\circ}$ C for every dissipated Watt. This value can be enough for moderate auditions, considering that the musical signal have a lower power spectrum than the pure sine wave, but the idle power dissipation, especially for BBM values of 80nS should be considered. For better cooling, a standard 5V CPU 60 x 60 mm cooling fan can be used. There are screw holes into the heat sink which can be used for fixing the fan. The TA3020v3c amplifier contains on-board fan speed controller which will supply the fan with a temperature dependent voltage, to adjust the fan speed and the airflow through the heatsink fins without a creating audible noise when the forced air cooling is not required. The connector for the fan can be found on the bottom right corner of the board next to the Signal input connector.

Layout: The PCB Layout design has an important contribution to the overall performance of the TA3020 Audio Amplifier Module. That's why double layer, FR-4 material with 1.6mm thickness and copper tracks thickness of 70um or 2 oz was chosen. The tracks width, were calculated to withstand the currents which they have to carry, and also the distance between adjacent tracks which carries higher voltages than 50V is big enough to satisfy the clearance conditions imposed by the design standards. The size of the PCB is 100 x 130 mm or 4 x 5.2 inch, and has 5 mounting holes, 4 holes are on the corner of the PCB and one at the top-middle side of the PCB. The mounting holes are 3.2mm diameter or 0.12 inch, copper plated and reinforced with 8 vias around the main hole, for better mechanical strength. The main components layout and the Input and Output connectors pin out can be seen in the Figure 4. The central mounting hole is connected to GND. The layout is symmetrical for Left and Right channel with respect to center axis, for better performances and aesthetical reasons. The heat sink is mounted directly onto the PCB and does not require additional support. Also the pinout for the input and output connectors can be seen. It is recommended to use heavy gauge wires for Power Supply and Loudspeaker Output and short shielded cables for Audio Input.

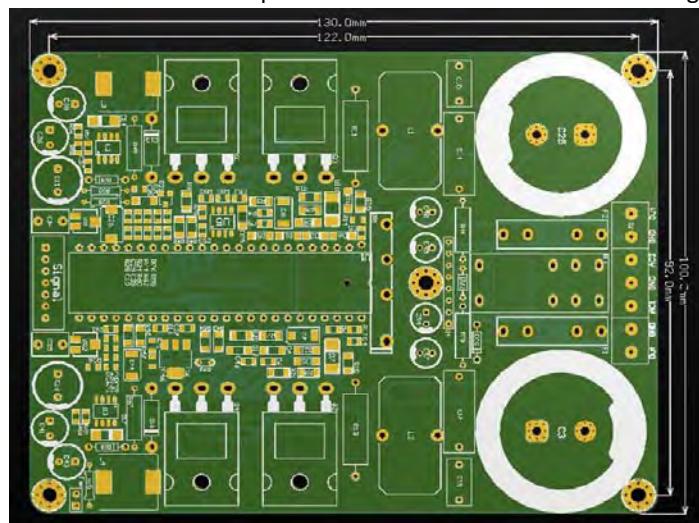

Figure 4: TA3020 Audio Amplifier module Board layout overview and connections

Speaker protection circuit: During turn ON and OFF, the amplifier may generate turn ON and OFF noise such as Click and Pop noises, frequently caused by external circuitry of the amplifier, such as input stages or power supply, or charging the input capacitor to the normal bias voltage. The solution which completely eliminates this problem is the on-board integrated Speaker Protection circuit. It is based on the very popular circuit uPC 1237, which contains all the necessary stages needed for efficient and reliable smooth turn ON-OFF and also speaker protection in case of power stage failure. The principle of operation is relatively simple, the relay is connected between the amplifier output and the loudspeaker, and the relay is connected with a delay of about 5 seconds after the power supply voltage has been correctly applied to the board. In this time, the amplifier transient noises are gone and the amplifier is ready for normal operation. When the power supply is turned off, the speaker protection circuit disconnects the loudspeakers from the amplifier, preventing the audible noise which might occur when power supply voltage decrease under a certain value and the amplifier might become unstable. One of the most important speaker protection features is the loudspeaker protection in case of DC component on the amplifier output. If the amplifier will have DC component at the amplifier output, the speaker protection will disconnect the loudspeaker from the amplifier, protecting the speakers from dangerous DC levels. To restart normal operation, must toggle the supply voltage or Mute pin.

To prevent the Click-Pop noise or the whistle at turn off when the amplifier is supplied with DC voltage instead of AC voltage, such as supplied from a SMPS and the rectifier Bridge bypassed, the amplifier Speaker protection circuit must detect the supply voltage drop below 40V DC in order to disconnect the speakers before the noise can occur. This can be done very easy, by replacing the diode D19 currently a 1N4148 type diode with a 39V or 43V Zenner diode, mounted reversed compared with the 1N4148 type.

Balanced Input Phase Shifter: In some cases, the amplifier is used with balanced input signals, and for this, the **BIPS** board must be used. Besides the main advantage of providing the balanced input option for the amplifier, it has the advantage that will reduce the Bus-pumping due to the fact that the signal is 180* shifted for one channel. The BIPS board requires a differential voltage in range of +-25 to +-60V at max. 10mA for proper operation and this voltage can be derived from the main amplifier supply voltage. The volume potentiometer can be connected between the **BIPS** and the TA3020v3c amplifier, allowing the master volume to be adjusted both for balanced and unbalanced inputs in the same time.

Application Information:

The TA3020v3c Audio Amplifier Module can be connected in several configurations, depending on the system requirements. The most common and simple configuration uses **EMI filter, Power Soft-Start Circuit, Mains transformer, BIPS** circuit if balanced input or BTL operation is needed. Then input-output connectors, a potentiometer, and optional Mute Button and LED indicator. The amplifier can be supplied either with AC voltage, from a mains transformer, which can provide 2x30V AC to 2x43V AC at minimum 5A for the lower power version or 8A for the higher power version. The main transformer AC voltage output must be connected at the pins AC1 and AC2 and the centre tap at GND. In the primary side of the mains transformer is strongly recommended the use of the **Power Soft Start** and a mains Switch capable to disconnect the full mains current when the amplifier is not used but connected to the mains.

If a SMPS is chosen instead of a mains transformer, the rectifier bridge must be bypassed to allow using the total capacitance of the **TA3020v3c** Amplifier plus the **SMPS** board capacitance. This will improve the transient response, will reduce the bus pumping and the sound will be more natural with deeper bass and transparent middle and high frequencies. The most suitable SMPS for the **TA3020v3c** Amplifier is **SMPS800R** +-60V version, with the voltage adjustable in range of aprox. +-56V to +-62V suitable for both 300W and 400W amplifier versions. The **SMPS800R** has on-board mains **IEC** connector, and can be installed on the back of the amplifier housing directly. In this case, the external EMI filter is not required, the **SMPS800R** has on-board **EMI** filter.

If a mains transformer is used, for best performances and low noise, it is strongly recommended that the **Power Soft-Start** board to be supplied with mains voltage through a standard EMI filter, such as **CW1D-6A, CW2A-10A** or **BIT IF-0633-W** depending on the required current at the available mains voltage. A broad selection of EMI filters can be found on the website, at the address: http://connexelectronic.com/index.php/cPath/21_26

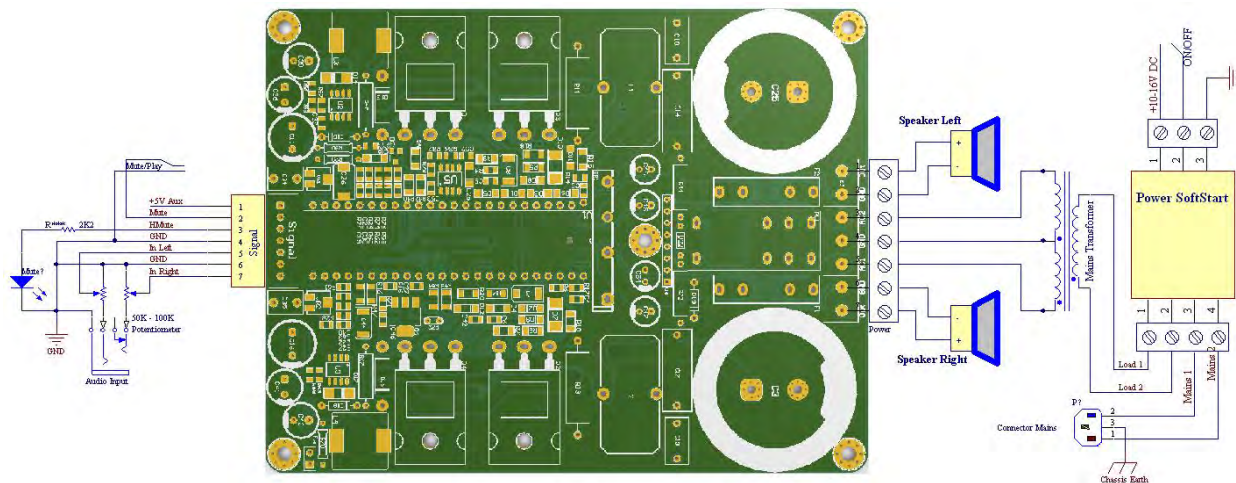

Figure 5: TA3020v3c Amplifier Basic Connection Diagram

If two or more amplifiers are installed in the same enclosure, or the amplifier will be used in BTL mode, thus the output power will exceed 1500W, a larger power supply must be used, such as **SMPS2000R**. This power supply can supply one **TA3020v3c** amplifier running in BTL mode, which will require approx. 1800W at maximum power, or two **TA3020v3c** amplifiers running in SE mode, 400W version each, or up to 3 **TA3020v3c** amplifiers 300W versions. The output voltage of the **SMPS2000R** must be in range of +56V to +61V for safe and reliable operation without compromising the output power, sound quality or performances.

Wiring the amplifier to connectors, potentiometers, transformers, auxiliary boards, must be done with proper size wires and the cables must be laid carefully to avoid parasitic couplings, both capacitive and inductive, which will degrade the S/N ratio and amplifier performances. The input cables should be wired with shielded cables as short as possible, far from the amplifier output section or **SMPS**. Note that the default signal cable which comes with the **TA3020v3c** amplifier is not shielded and can be used if the length of wires does not exceed 10 cm and they are routed further away from the power stage. Do not add extra wires to the existing ones if the length is not enough, instead replace them with shielded wires. The power connections, to the loudspeakers and **SMPS** must be wired with wires which are able to carry currents in excess of 10A. **Attention** must be paid to insulation, especially for the mains powered wires, where double insulation wires must be used.

Connectors Pinout:

The **Signal** input connector pinout is as follows:

- Pin 1: 5V supply from the TA3020v3c board to aux circuits, or mute control and LED's max. 50mA
- Pin 2: Mute In – a logic 1 on this pin will bring the amplifier in Mute state.
- Pin 3: Mute Status – this pin will toggle to logic 1 is when the amplifier is Muted
- Pin 4: GND Signal
- Pin 5: Input Left – audio signal Input Left
- Pin 6: GND Signal
- Pin 7: Input Right – audio signal Input Right

The **Power** connector pinout is as follows:

- Pin 1: Right Loudspeaker Output
- Pin 2: GND Power
- Pin 3: AC1 or V+
- Pin 4: GND Power
- Pin 5: AC2 or V-
- Pin 6: GND Power
- Pin 7: Left Loudspeaker Output

The **FAN** connector pinout is as follows:

- Pin 1: Fan+ (close to the edge of the board)
- Pin 2: Fan- (towards inside of the board)



Warning:

Before you proceed with installation, make sure you have read this warning:

The TA3020v3c contains potentially hazardous voltages up to 130V DC or 100V AC. This voltage levels are present on the top and bottom of the board, and during installation and operation should never touch any part of the board while it is connected to the mains and at least 5 minutes after complete disconnect from mains. If any adjustment or reconnection needs to be done, disconnect the unit from the mains and allow all capacitors to discharge for at least 5 minutes before handling it. Any ignorance of this warning will be made on user's responsibility, and can lead to serious injuries and possible death by electrocution if is handled improperly. This product has no serviceable parts other than the on-board mains fuse. In case of blown fuse, only replace the fuse with the same type and rating. Do not attempt to change any other component from the board. A safety clearance of at least 6mm must be kept between the board and the case, or any conductive part of the amplifier.

For best performances and long term reliable operation read before proceed!!!

Peaking phenomenon will occur when the amplifier input is connected or disconnected while the amplifier is powered ON or the input is touched by hand to "test" if the amplifier is working. This is a very stupid mistake for any kind of amplifier, as the body static voltage corroborated with the voltage induced by the near electromagnetic field, less than ideal mains to amplifier ground isolation, will lead to high voltages build-up usually tens of volts which have 90% chances to damage any kind of amplifier with input impedance bigger than 10KΩ. Although the mains hum is dominant when "testing" the amplifier using this rude method, there is a full, rich spectrum of frequencies up to tens or hundreds of KHz, something which any normal amplifier should never expect. To prevent the amplifier failure, and making it "idiot-proof", a more or less complex circuit can be employed but this will reduce its performances and sound quality, and due to this fact we strongly believe that the user know what he's doing and will avoid torturing the amplifier for its own good.

Although the amplifier comes with optimized components, yet some peoples still want to "improve the improvements". The very common mistake found on Class D and T amplifier while tuning the amplifier, is to replace the input capacitors with bigger size, sometimes as big as a coke can input capacitors. This is one of the biggest mistakes which can be possibly done on such amplifier. Not only that these placebo capacitors will not improve the sound, they will make it worse, and in some cases will damage the amplifier. Because as I wrote few rows above, the input should not be touched by hand or tools while is working, NEVER!!! (and this is often done during the tuning process) and these capacitors with their large volume and area will act like antennas which will pick-up the switching noise from the power stage, from the power supply, from environment, and also common mode noise from the amplifier housing if is made of metal and they are touching the case, even without electrical contact due to the stray capacitance between the capacitor and metal parts in close proximity.

Disclaimer:

The TA3020v3c Audio Amplifier shall be used according with the instructions provided in this document. The user should NOT attempt to modify or change any of the parameters of this product, which can lead to malfunction. The designer and manufacturer of the product, PCBstuff, and the official distributor, Connexelectronic, will not be liable for any kind of loss or damage, including but not limited to incidental or consequential damages. Due to the mains voltages of this board, the user should take all the caution measures needed when working with mains voltages, should not touch any unisolated part of the board or connectors, or short-circuit any part of the board or connectors. Any misuse will be made on user responsibility.

The designer and manufacturer PCBstuff reserve the right to make changes or modifications on both the product functions and performances without notice. The Power Soft Start Circuit schematic and PCB design is PCBstuff proprietary and shall not be distributed, copied or published without the PCBstuff written agreement. PCBstuff and Connexelectronic reserve the right to offer limited support for the boards purchased directly from PCBstuff or Connexelectronic, and no support at all for the similar boards which aren't purchased directly from PCBstuff and Connexelectronic, or future listed resellers, and from various reasons they look or pretend to be similar, exactly same, or improved version products. Purchasing the product means that you are aware and agree with all this conditions.